

1 Safety

These installation instructions support the safe installation of the G4 Mounting plate pro for use in accordance with the intended use:

The G4 Mounting plate pro is designed for the long-term but detachable mounting of the G4 series lithium batteries in vehicles.

Observe the following safety instructions.

CAUTION! Risk of injury due to trapped fingers during assembly.

2 Scope of delivery

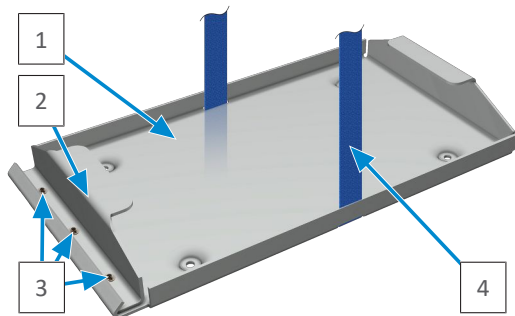

1 Mounting plate	2 Retaining clamp
3 Cheese head screw TX M5×6 (3 pcs.)	4 Tensioning strap 25 mm × 1.4 m with clamp lock

3 Technical specifications

Variant	100 Ah	280 Ah
Part number	1051009041	1051009042
Material	Stainless steel 2 mm	Stainless steel 2 mm
Dimensions (L × W × H)	356.5 × 202 × 50 mm	453.5 × 202 × 50 mm
Weight	1.62 kg	1.98 kg

4 Assembly

4.1 Preparation

WARNING! Device defect due to incorrect installation.

Observe the requirements for the installation location in the vehicle:

- Choose a stable, horizontal platform that is firmly integrated into the vehicle.
- Make sure that a screw connection with threaded bolts and nuts (M6) is possible at the installation location.

WARNING! Do not use self-tapping screws or wood screws.

NOTE! If the rear of the mounting surface is not accessible, LEAB recommends the use of drive-in nuts or blind rivet nuts.

- Ensure that there is sufficient space at the installation site for the installation and subsequent operation of the G4 lithium battery and the connecting cables.

4.2 Installation

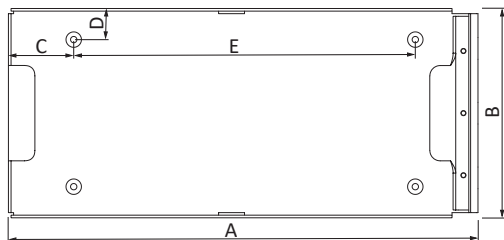

Dimensions	100 Ah	280 Ah
A	356.5 mm	453.5 mm
B	202 mm	202 mm
C	47.5 mm	63 mm
D	30 mm	30 mm
E	239 mm	330 mm

1. Mark the positions for the 4 drill holes at the desired installation location. Use the mounting plate [1] as a template.
2. Drill the holes and prepare them for screwing.
3. To attach the G4 lithium battery later, guide the tensioning strap [4] underneath the base of the mounting plate through the two slotted holes on the side.
4. Screw the mounting plate to the mounting surface.
⇒ The installation of the mounting plate is complete.

5 Usage

NOTE! Please also refer to the user manual for the G4 lithium battery.

1. Unscrew the 3 TX M5×6 screws [3] to remove the retaining clamp [2].
2. Install all connecting cables that are no longer accessible after inserting the G4 lithium battery into the mounting plate.
3. Push the G4 lithium battery lengthways into the mounting plate until it reaches the end stop.
4. Reinsert the retaining clamp so that its upper retaining tab protrudes into the carrying recess of the G4 lithium battery.
5. Screw the retaining bracket tight with the 3 TX M5×6 screws (recommended tightening torque: 6 Nm).
NOTE! To prevent unintentional loosening of the screws, use a screw locking lacquer, e.g. Loctite243.
6. Fasten the G4 lithium battery with the tensioning strap [4].
7. Connect all required cables to the G4 lithium battery.
⇒ The G4 lithium battery is installed in the vehicle with the mounting plate.